



Natural Gas Water Heater



User manual and
installation instructions



WARNING

This manual contains data and information for both the user and the installer.

The user should look at the following chapters in particular: General warnings and safety, Flue gas device, Control panel.

Please keep these instructions safe near the unit or gas meter for future use.



DANGER: Instructions marked with this symbol must be observed to prevent mechanical or generic accidents (e.g. injuries or bruises).



DANGER: Instructions marked with this symbol must be observed to avoid electrical accidents (electrocution).



DANGER: Instructions marked with this symbol must be observed to avoid the danger of fire or explosions.



DANGER: Instructions marked with this symbol must be observed to avoid heat-related accidents (burns).



WARNING: Instructions marked with this symbol must be observed to avoid malfunctions and/or material damage to the unit or other items.



WARNING: Instructions marked with this symbol contain important information that must be read carefully.



GENERAL WARNINGS



The instructions manual forms an integral part of the product and therefore must be carefully retained and always kept with the unit; if lost or damaged, a copy of these may be downloaded from the manufacturers web site www.evolvebathrooms.co.uk

- ✓ **Installation of the unit and any other service or maintenance operation** must be carried out by a Gas Safe registered installer.
- ✓ **The unit must be used for the purpose envisaged by the manufacturer.** No contractual and extra-contractual responsibility can be taken for damage caused to people, animals or things, as a result of installation, regulation and maintenance errors or improper use.
- ✓ **The safety or automatic regulation devices of the unit** must not be modified.
- ✓ **This unit is used to produce hot water**, it must therefore be connected to a domestic hot water distribution network compatible with its performance and power.
- ✓ **In the event of a water leak**, turn off the water supply and promptly notify your Gas Safe registered installer.
- ✓ **If away for a long time**, turn off the gas supply. If there is the risk of freezing, empty the water heater of the water it contains.
- ✓ **In the event of a fault and/or poor operation of the unit**, turn it off, refraining from any attempt to repair it or any direct intervention.
- ✓ **Maintenance of the unit** must be carried out at least once a year: this may be undertaken by any Gas Safe registered engineer.

BASIC SAFETY RULES

The use of the unit requires strict observance of some basic safety rules.

- ✓ **Do not use** the device for purposes other than those for which it is designed.
- ✓ **It is absolutely prohibited** to obstruct the flue terminal grills and the ventilation opening of the room in which the unit is installed, with rags, papers or anything else.
- ✓ **If a smell of gas is detected**, do NOT activate electric switches, the telephone and any other object that might cause a spark. Air the room by throwing doors and windows wide open and turn off the gas at the mains. Contact the national gas emergency helpline on 0800 111999.
- ✓ **Do not rest objects on the unit.**
- ✓ **Do not leave containers and flammable substances** in the room where the unit is installed.
- ✓ **Any attempt at repair is prohibited** in the event of a fault and/or poor operation of the unit.
- ✓ **Use of the unit by children or inexperienced people is prohibited.**
- ✓ **Tampering with the sealed elements is prohibited.**

TABLE OF CONTENTS

1. Important Information	6
1.1 Features and Benefits	6
2. Specifications	7
2.1 Technical Data	7
3. Description of Unit	8
3.1 Parts Name	8
3.2 Electrical Digram	9
3.3 WH30 Dimension	10
4. Display Information	11
4.1 Display Content Instruction	11
5. User Instructions	12
5.1 Preparation before ignition	12
5.2 Temperature Setting	12
5.3 Ingition & Water outlet	12
5.4 Attention	12
5.5 User Function Mode	13
5.6 Instant hot water production and real time gas consumption display	13
5.7 Check the cumulative amount of gas and water	14
5.8 Safety Cautions	14
5.9 Gas accident prevention	15
5.10 Fire Prevention	16
5.11 Carbon Monoxide toxicosis prevention	16
5.12 Abnormal Condition	16
5.13 Scald Prevention	16
6. Installaion	17
6.1 Installation	17
6.2 Packaging and accessories	17
6.3 Installationequirements	17
6.4 Installation method	18
6.5 Installation of water and gas pipes	19
6.6 Installation of the flue	20
6.7 Cautions for flue installation	22
6.8 Conversation Instructions	23
6.9 Technical instruction	24
6.10 Volume parameter settings	26
6.11 Gas pressure at the burner	26
6.12 Gas pressure at the burger	26
6.13 Gas Type Setting	26
7. Maintinance	27
7.1 Maintinance	27
7.2 Cleaning	27
7.3 Trouble-shooting guidance	28
7.4 Explanation of the Error Codes	29
8. Packaging and Accesories	30
9. Gas Water Heater Disposal and Recycling	31
9.1 Gas Water Heater Disposal and Recycling	31
10. Wattanry	32
10.1 Wattanry Conditions	32
10.2 Guarantee Conditions	32

1. IMPORTANT INFORMATION

1.1 FEATURES AND BENEFITS

Micro-computer intelligent control system

The core component of the gas water heater is a micro computer intelligent control system, which is one of today's most advanced mechatronic technology. The CPU chipset can analyze automatically and set the optimal working parameter rapidly according to different data such as the flowing water quantity, the pressure situation and the actual inlet water temperature.

Digital control for automatic constant temperature of outlet water

This function is to monitor the outlet water temperature by a temperature sensor and to transfer the information to the micro-computer, so that the micro-computer can adjust the gas and air supply quantity to guarantee the constant outlet water temperature according to the temperature set by the user and the actual inlet water temperature automatically.

Pressure

The lowest start-up water pressure of this product could reach 0.02 MPa (0.2 bar) (or a minimum flow rate of 2.5 L/min), so it could also be used in the residence area with low pressure.

"AI" Artificial Intelligent Memory Function

The water heater remembers the last set point temperature removing a need to re set every time the unit is activated.

Energy saving

This product has advanced technologies called Strengthened Combustion and Forced Combustion.

These features aim to make the best use of heat energy with high working efficiency.

Set temperature by touch

You can set the required temperature easily by touching the digital display. The temperature range is from 35°C to 65°C.

Multiple safety protection

This product has built in safety protection, this includes self-check protection, flame-out protection, over-heat protection, accidental power-cut protection, fan breakdown protection, electric overload protection, electric leakage protection, high wind pressure protection and over temperature protection.

Tips

The above conclusion comes from the safety protection test under lab conditions.

It may be affected by the surroundings in its actual place of installation. Thus, please use the product in proper conditions.

2. SPECIFICATIONS

2.1 Technical Data

Name		Domestic Gas Instantaneous Water Heater
Model		WH30(JSG16ST-S21)
Nominal Heat Input(Hi)		30kW
Nominal Heat Output		27.4kW
Minimum Heat Input		9.5kW
Minimum Heat Output		8.7kW
Max Flow Rate(rise 25)		16L/min
Appliance Type		C13,C33
Gas Type		2H-G20-20mbar Only
Gas Category		I2H-G20-20mbar
PIN Number		0063CR7772
Max Water Pressure		Pw=10bar
Min Water Pressure		Pw=0.2bar
Electrical Power Supply		230V~,50Hz
Electric Power		44W
Degree of Electrical Protection		IPX4
Ignition method		Water Control Automatic Pules Ignition
Destination Country		GB
Pipe Joint	Gas Inlet	G1/2
	Cold Water Inlet	G1/2
	Hot Water Outlet	G1/2
Flue Duct Diameter		Φ100(external), Φ 60(internal)

Table 2.1

3. DESCRIPTION OF UNIT

3.1 Parts Name

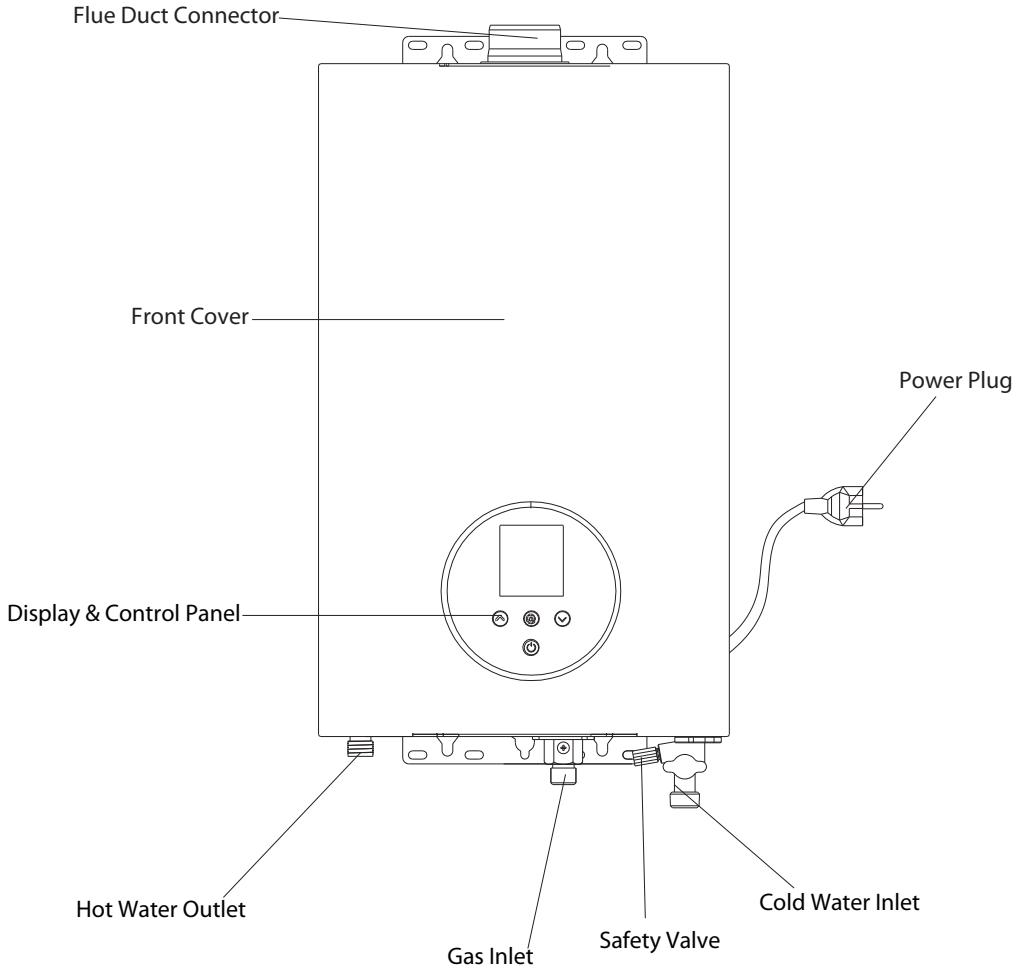

Figure 3.1

(The dimension information is for reference only. Please refer to the actual product.)

3. DESCRIPTION OF UNIT

3.2 Electrical Diagram

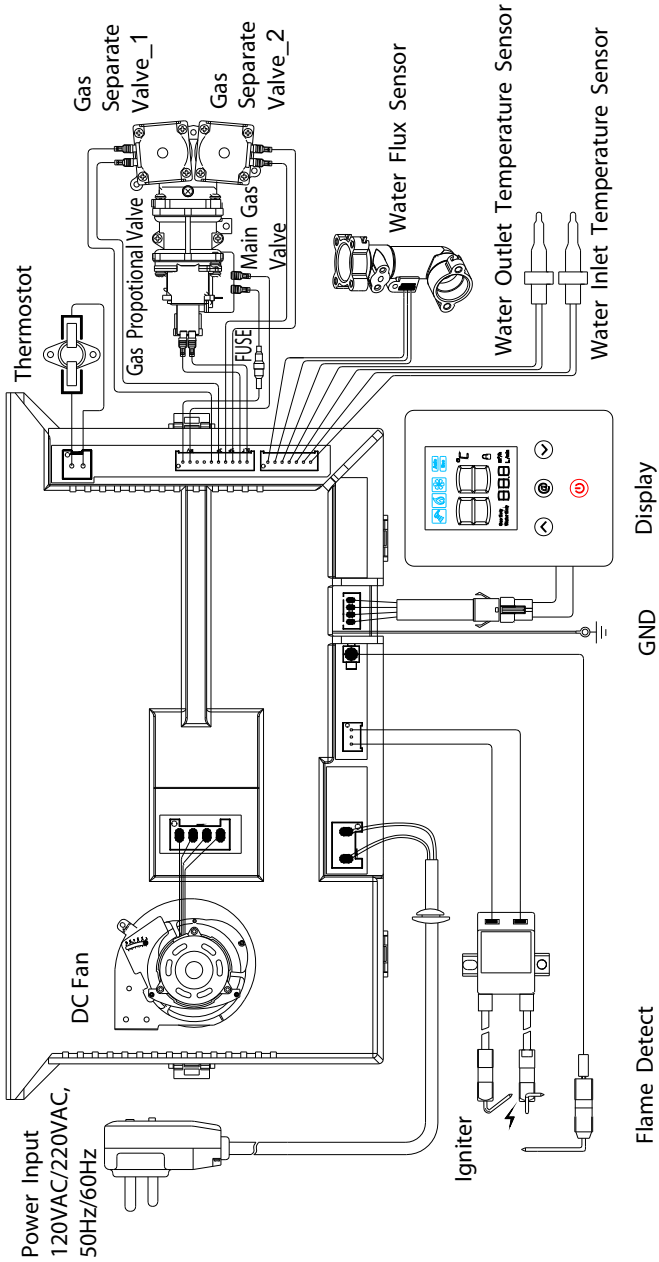
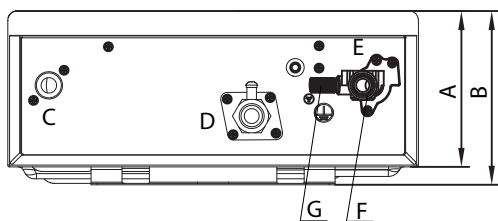

Figure 3.2

3. DESCRIPTION OF UNIT

3.3 WH30 Dimension



Model	WH30 JSG16ST-S21
A	170
B	185
C	Hot water outlet 1/2"
D	Gas inlet 1/2"
E	Cold water inlet 1/2"
F	Cold water inlet filter
G	Safety valve discharge

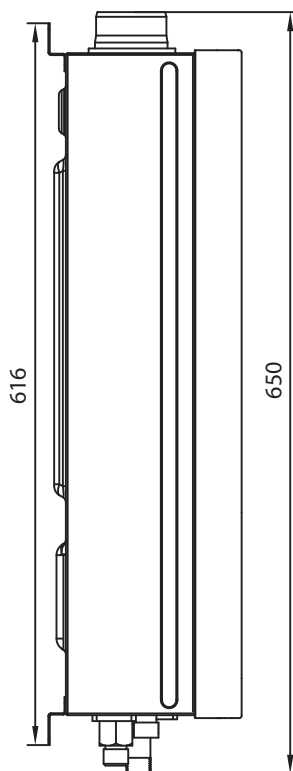
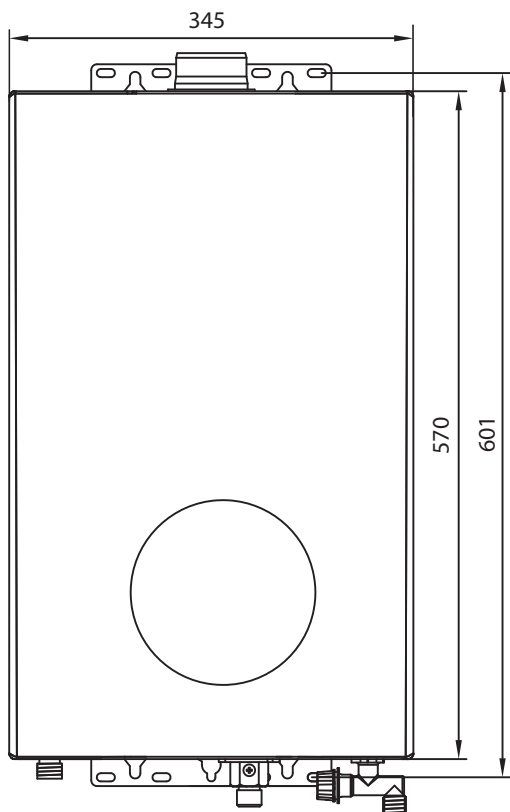

Figure 3.3

All dimensions are in mm.

(The dimension information is for reference only. Please refer to the actual product.)

4. DISPLAY INFORMATION

4.1 Display Content Instruction

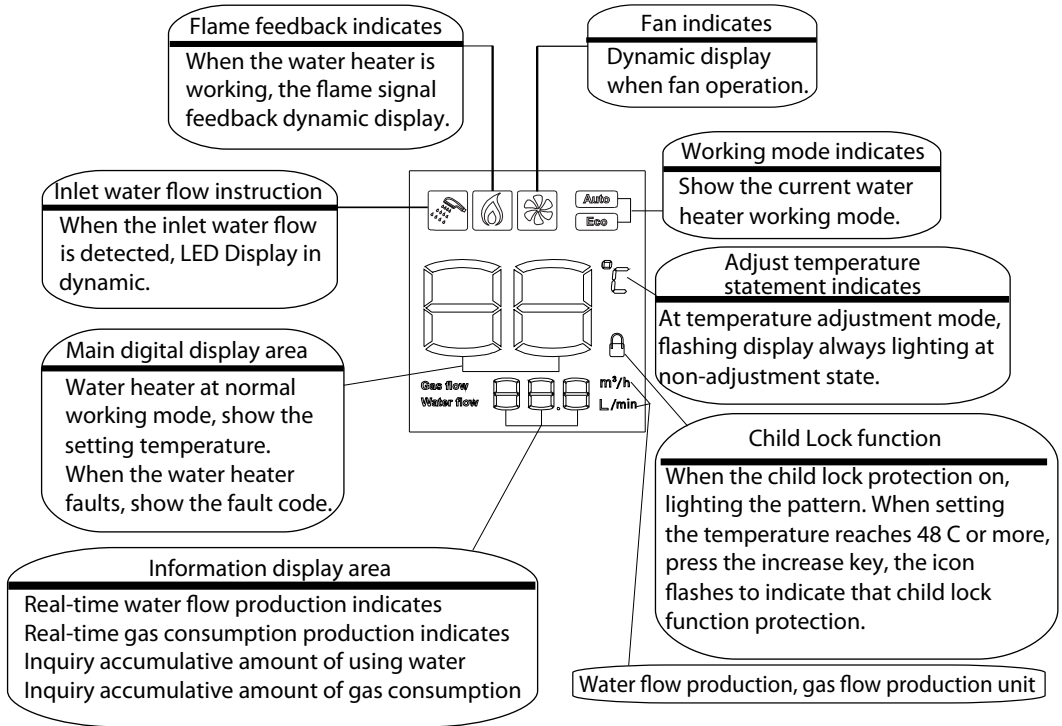

- Touch button instructions(the position of the touch button may change according to different models)

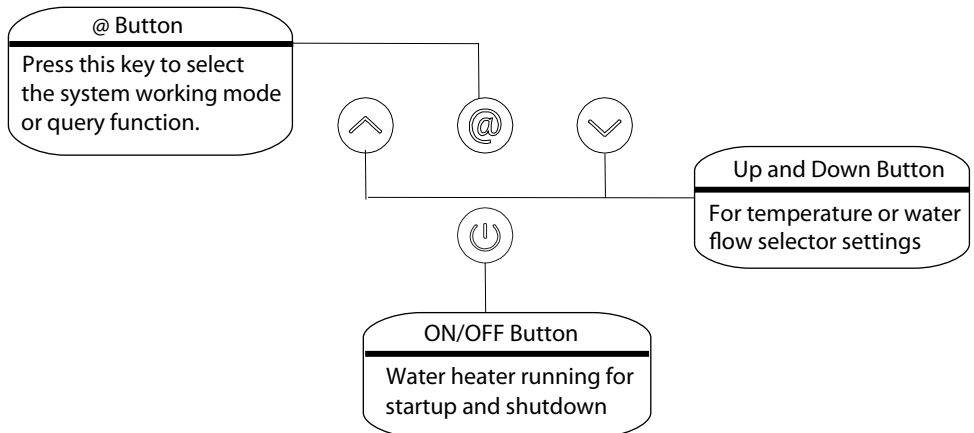

Figure 4.1

5. USER INSTRUCTIONS

5.1 Preparation before ignition

- Make sure that the gas used is in accordance with the gas stipulated on the data label.
- The electric installation must comply with technical standards, in particular:
 - It is **mandatory** to connect the gas water heater to an effective earthing system via a specific terminal.
 - A switchable fused spur must be installed near the gas water heater to allow complete isolation in conditions of category III over-voltage.
- Switch on the power to the gas water heater (The buzzer sounds “bi”).
- Turn on the gas valve.



If the power supply cable is damaged, it must only be replaced by a qualified technician.

5.2 Temperature Setting

- Press the **On/Off** key on the control panel, the screen will display the default hot water temperature. Press **Up** or **Down** to set the hot water temperature as desired. The lowest hot water temperature of this product is 35°C, highest is 65°C. From 35~48°C each time you press the button it will change by 1°C. From 48~65°C each time you press the button it will change 5°C (48°C, 50°C, 55°C, 60°C, 65°C).

5.3 Ignition & Water Outlet

- When a hot water outlet is opened the inlet water flow will show the draw off icon on the display screen. The display shows the set temperature of outlet water.
- When in use the flow temperature can be adjusted. When you turn the hot water on for the first time you can only adjust the temperature between 35-48°C (child lock function to prevent burns). If you want to set the temperature higher than 48°C you must turn off the hot water demand first, then you can

increase the temperature before turning on again.

When a water outlet is open, but the switch stays in the **OFF** position, the water heater will stop working, and only cold water runs out. If hot water is needed, press the **ON** button.

- When the water heater is turned off the fan will continue to run for several seconds. The water heater will show the temperature set the last time it was use.

5.4 Attention:

- If the water outlet is open before the water heater is switched on, the gas water heater will go into a protective mode, and the buzzer sounds. Please close the water outlet.
- It might take several trial ignitions after installation or the first use after gas interruption to push out all the air remaining in the gas pipe.
- The temperature shown on the screen is the set temperature, while the outlet water temperature differs according to the length of pipes and different seasons. Therefore, please refer to the actual outlet water temperature.
- If hot water flow exceeds the water heater's capacity, the water may not be hot enough. Please reduce the water flow accordingly.
- Every time the water heater starts working, please pay attention to the set temperature on the display and be careful not to be scalded.
- In order to avoid being scalded, always verify the water temperature before use.
- Should the gas water heater stop working and the display shows error codes, please close the water valve and reopen. Or press the **On/Off** button until the machine is off, and then restart it. If the water heater still cannot operate normally, please turn off the gas valve and cut the power, recharge the machine and ignite again after a few minutes.

5. USER INSTRUCTIONS

5.5 Use function mode

In standby mode (ie, no water status), press the function (@) key, you can select "Auto", "Eco", "normal" in turn. The system default mode is set to **normal**.

Three types of function mode instruction

- **Normal** mode (default): This mode allows the user to set the temperature. The "Auto" and "Eco" display lights are not lit.
- **Auto** mode: ("Auto" display light is bright.) This mode will adapt the output temperature based on the water inlet temperature. This automatically adjusts the set temperature (as shown in Figure 5.5) allowing users to get the most comfortable hot water supply.

Temperature mapping table

N.	Local Water Temperature	Corresponding Temperature
1	≤ 15°C	45°C
2	16°C-21°C	43°C
3	22°C-27°C	40°C
4	≥ 28°C	38°C

Figure 5.5

Note: Under the Auto mode, after the water heater is switched on, the temperature displayed is the one set before the heater starts to work. The temperature will not change according to the local water temperature change after the heater starts to work.

- **Eco** mode: ("Eco" display light is bright.) In Eco mode, after calculation by the microcomputer the water heater automatically adjusts the amount of gas supply. This not only saves gas, but can also guarantee a constant water temperature to meet the requirements of users. In the state of saving mode, the user can freely select the desired of setting water temperature, the user presses the up or down key to adjust the setting temperature does not exit the power saving mode, in this case the

user needs in the standby mode press the function key again to exit the power saving mode.

5.6 Instant hot water production and real time gas consumption display

When the water heater is working, the display will take turns showing the current real time hot water production and real time gas consumption, the figures will be changed according to the actual working conditions, so that users can understand the water heater current working conditions.

For example: When the real time information display "12.0 L/min", this indicates that the real time hot water production is 12L per minute. When the real time information displays "2.0 m³/h", this indicates that current real time gas consumption per hour is 2.0 m³.

Real-time gas consumption

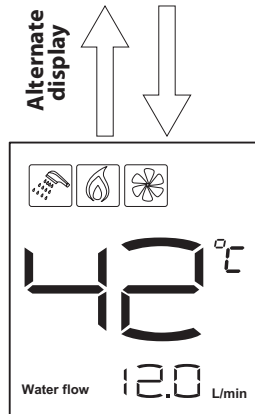
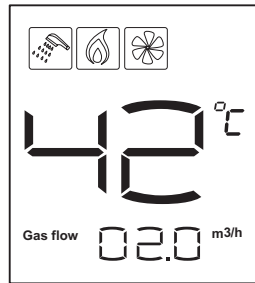

Figure 5.6

Real-time hot water production

5. USER INSTRUCTIONS

5.7 Check the cumulative amount of gas and water

The @ button can inquire about the cumulative water and gas consumption. Click the @ key to query cumulative amount of water usage, press @ key again to display the accumulated gas consumption information. Press a third time or do not touch for 20s and you will exit this function.

Note:

- Real-time gas consumption is shown in units of m^3/h .
- Real-time hot water production is shown in units of L/min.
- The total amount of gas and water consumption is shown in m^3 . When the counter has reached $999 m^3$ it will automatically reset to 0.
- Cumulative gas consumption and cumulative amount of water is automatically cleared after power failure.
- The contents of this function is only for reference, can not be used for metering measurements.

5.8 SAFETY CAUTIONS

Prevention of freezing

Drain the residual water inside the heater to prevent freezing after every use when the environment temperature is near or under $0^{\circ}C$, do as instructed. (Figure 5.8)

- Close down the gas valve 1.
- Turn the water temperature knob 2 to "LOW" position, or turn the water volume button knob to "LARGE" position (level).
- Close the cold water inlet valve sans 3.
- If there is a control valve 4 at the hot water outlet, please open it.
- Turn the drain valve 5 and take off, replace it after the residual water is completely discharged.

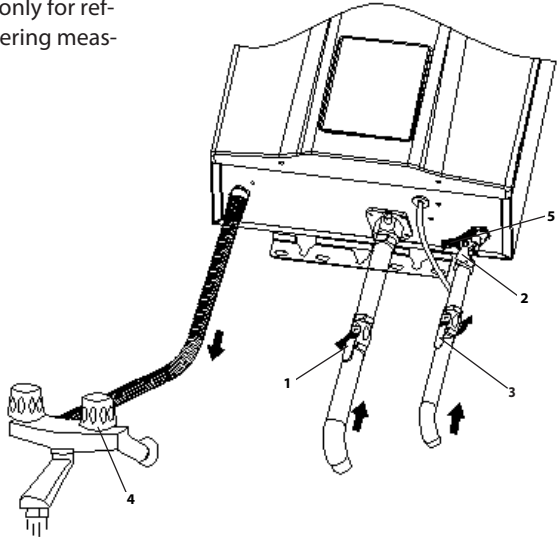

Figure 5.8

- 1 Gas valve
- 2 Water volume knob
- 3 Water volume

- 4 Control valve
- 5 Drain valve

5. USER INSTRUCTIONS

5.9 Gas accident prevention

- Check if the burner is out after use and do not forget to turn off the gas valve and power if the burner fails to extinguish.
- Always check the gas connectors for gas leakage with leak detection fluids. If any gas leakage is detected, open the room windows and doors. At that moment, do not ignite or operate the switch of electric appliances or plugs because the flame or electric spark can cause an explosion.
- Heaters must use the gas type which the heater is designed to use, different type of gas must not be used.
- If the flame goes unsteady, stop using the water heater and contact your qualified gas safe registered installer or service engineer for repair or adjustment.



Turn off gas after use.
Open the window in case you can smell gas.
Don't touch electric switch.

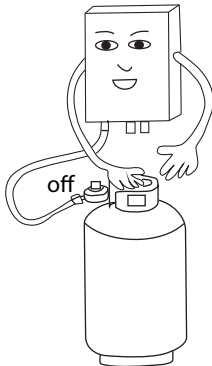

Turn off gas after use.

Figure 5.9-1

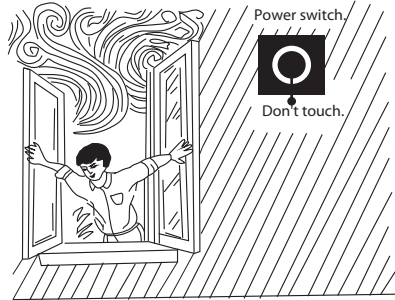

Open the window in case smelling

Figure 5.9-2

5. USER INSTRUCTIONS

5.10 Fire prevention

- Do not leave the water heater unattended whilst in operation.
- In case of power failure or water failure, turn off the gas valve and water inlet valve.
- Do not place towels or clothes on top of the water heater.
- Do not store flammables, explosives or volatiles near the water heater.
- Never incline the gas cylinder or turn it upside down.



Do not hang anything on or overhead.

Do not store flammables, explosives or volatiles near the water heater.

Do not hang thing on or overhead

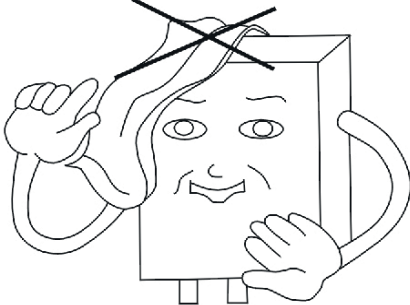

Figure 5.10-1

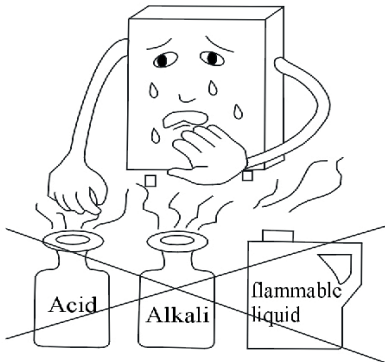

Figure 5.10-2

5.11 Carbon Monoxide toxicosis prevention

- This product must exhaust the waste gas outdoors so the flue duct must be connected to the joint on the top of the water heater to exhaust the waste gas out to an outdoor area. Otherwise, it will cause danger or even death.
- Too low or too high gas pressure leads to abnormal combustion. At that moment, stop using the water heater and get in contact with a gas safe registered professional.
- Dust and accumulated carbon would block the heat exchanger due to long periods of use, and affect the combustion performance, causing Carbon monoxide to increase. Therefore, contact a qualified person to clean and clear the dust and accumulated carbon every year to ensure the combustion product discharges smoothly.
- The heater must be installed vertically, if inclined it will make the flame touch the heat exchanger and cause incomplete combustion.

5.12 Abnormal conditions

- If there is abnormal operation such as: (flame light-back, flame lift, yellow tip or black smoke, etc), smell or noise, or other emergent situations, keep calm and shut off the gas supply valve and power switch, and contact the manufacturer or a gas safe registered professional for repair or adjustment.

5.13 Scald prevention

- When the use of the water heater is not continuous be careful not to be scalded by high temperature hot water at the start and stop times.
- During use and immediately after, do not touch the water heater except the control panel in order to prevent scalding



Warning: Any interference with a sealed component is forbidden, a fire or explosion may result causing property damage, personal injury or loss of life.

6. INSTALLATION

6.1 INSTALLATION

Contact your local gas safe registered installer who must also be qualified to work on gas water heaters (users are recommended not to install by themselves). The installer should be called on to install and adjust the appliance, where appropriate.

It is prohibited to use this gas water heater when the flue pipe has not been installed correctly according to instructions.

6.2 Packaging and accessories

Description	Quantity
Gas water heater	1
Expansion screws	1
Mounting screws	2
User manual	1
Self-tapping screws	2
Flue duct (C13 type) (optional)	1

6.3 Installation requirements

- The flue of the gas water heater should be installed through an external wall, the heater cannot be installed outdoors (Figure 6.3-1)

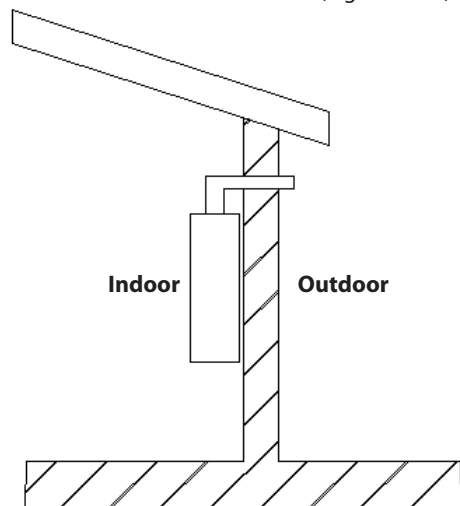

Figure 6.3-1

- The gas water heater installed in a suitably ventilated room, in accordance with the regulations in force.
- The flue of the heater cannot be connected to a common flue (Figure 6.3-2)

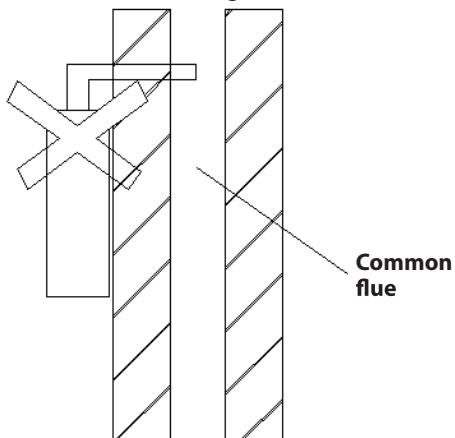

Figure 6.3-2

- Please don't install the heater in places where special chemicals are used, such as laundries or factories etc., otherwise it may cause rusting, shorten the lifetime of the heater, or prevent normal operation.
- Don't install the heater above the gas stoves or other heat sources (Figure 6.3-3).

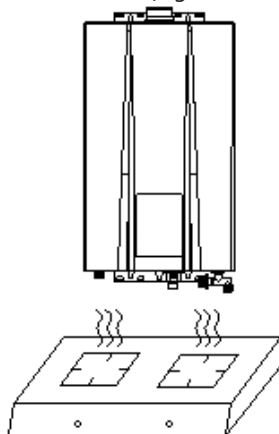

Figure 6.3-3

6. INSTALLATION

- The gas water heater should be kept away from combustible materials with the distance shown in Figure 6.3-4 at least.

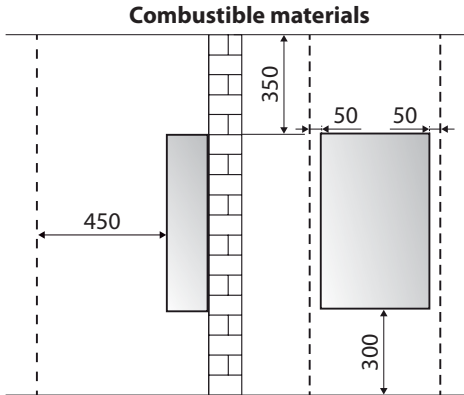

Figure 6.3-4

- When the installation area contains combustible material then a non combustible heat resistant mounting plate that exceeds the size of the water heater frame by at least 10 mm in all directions should be used (Figure 6.3-5).

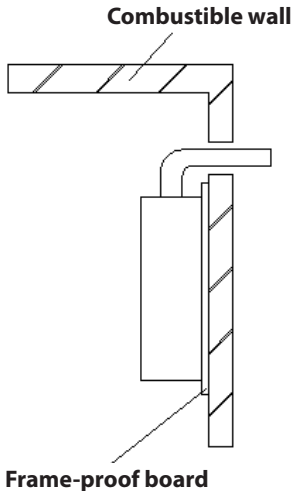

Figure 6.3-5

- The electric wires and electric equipment are not allowed to be placed on the top of the gas water heater. The horizontal distance

between the gas water heater and other electric equipment should be more than 400 mm.

- The power socket must have a reliable earth wire to improve safety. It is recommended that a neon fused switch socket is used. Whenever the water heater is not in use, please switch it off at the fuse spur. The power supply socket should not be installed in wet or damp areas.
- The socket should be installed at the side of the product, and never be installed below the machine or a place that is susceptible to splashes, near a heat source, in exposure to sun and rain, or the place where it is not easy to control.
- The installation of the spur should be in line with the current requirements of the IEE wiring regulations.

6.4 Installation method

Installation of gas water heater

- Drill holes in the wall according to Figure 6.4-1. Figure 6.4-2 and Figure 6.4-3, it is strongly recommended that strong fixings are used in the top and bottom securing holes.

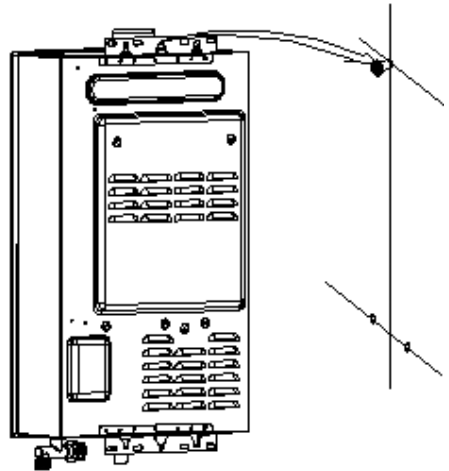

Figure 6.4-1

6. INSTALLATION

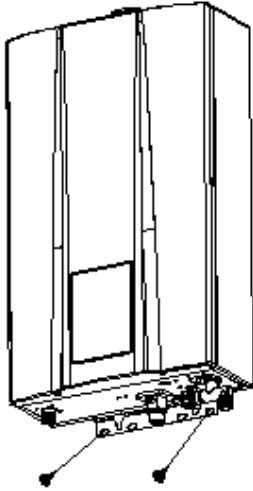

Figure 6.4-2

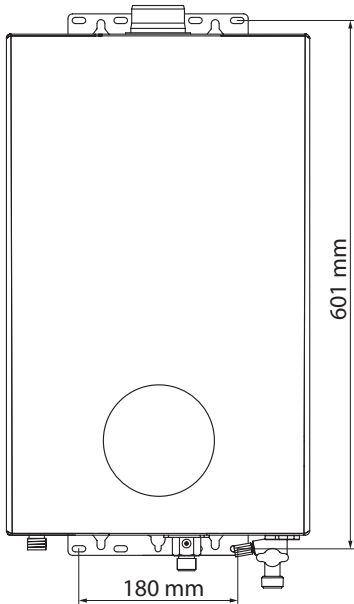

Figure 6.4-3

6.5 Installation of water and gas pipes

- It can be used when the flue system can ensure that the provided gas pressure can reach the lowest requirement. If gas water

heater reaches the rated heat input, the gas pressure must reach the rated heat input in the technological parameter form.

Evolve WH30

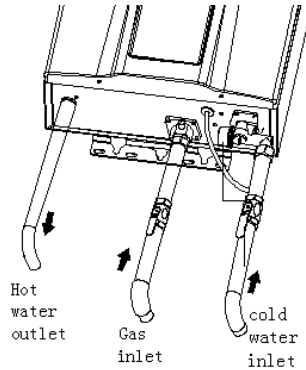

Figure 6.5

- Gas inlet
 1. Before connecting the gas supply, check the rating plate on the right side of the right front cover to be sure that the heater is rated for the same gas to which it will be connected.
 2. All such pipe shall be either new or previously used for no other purpose than conveying gas; and must be in good condition.
 3. When your connections are made, check for gas leaks at all joints (this includes all existing piping). Apply leak detection fluid to all gas fittings and gas valve. **Bubbles are a sign of a leak.**

NOTE: No substance other than air, National Gas can be introduced into the gas piping.

NOTE: If you have a leak, shut off the gas. After verifying the leak, tighten appropriate fittings to stop the leak. Turn the gas on and check again with a leak detection fluid. **Never test for gas leaks using a match or flame.**

- Cold water inlet
 1. When facing the heater, the cold water inlet is on your right and the hot water out-

6. INSTALLATION

let is on your left. Although water piping throughout your structure may be other than copper, we recommend that copper piping be used for at least 0.92 m before and after the heater. Keep water inlet pipe to no less than 1/2" diameter to allow the full flow capacity.

2. Remember that water pressure must be sufficient to activate the heater when drawing hot water from the top floor. If the hot and cold connections to the heater are reversed, the heater will not function. 1/2" copper or brass fittings work best when connected to the connectors. No pipe dope or thread tape is to be used at this joint. Be certain there are no loose particles or dirt in the piping (Figure 6.5).

3. Water pressure must be sufficient to activate the water heater, the maximum pressure for the appliance is 10 bar, even with the effects of water dilation, the water pressure in the appliance shall not exceed this value.

- Hot water outlet

1. It is recommended that copper pipe is used to connect the hot water outlet to the installation hot water distribution pipe work.

6.6 Installation of the flue

- Flue duct installation of forced-exhausted gas water heater (B23,B53 Type).

This product is forced exhaust type gas water heater; it can be used only after the flue duct is installed according to the requirements and can exhaust the waste gas to an outdoor area. It's not allowed to use the gas water heater without installing the flue duct correctly.

Please follow the below requirements during the installation of flue duct:

- (1) Please use the flue supplied by our company, referring to Figure 6.6-1 about the installation method. If the flue duct is too short, you can extend it aptly. Check the flue duct and see if there is any damage or leakage every half a year.
- (2) The length of the flue duct should be less than 8m,
- (3) The horizontal distance of the flue duct is the shorter the better. The flue duct end should have a 20 downward inclination (Figure 6.6-1), so as to let the condensing water flows out.
- (4) The distance between the flue duct and the combustible materials should be more than 150mm. If the flue duct needs to get through the combustible materials or wall, it should use the heat shield material to pack the flue duct with the thickness over 20mm. (Figure 6.3-4)
- (5) No cement between the flue duct and wall for the convenience of maintenance.
- (6) The flue duct should be fixed tightly. The connection part could use self-adhesive foil to avoid the waste gas going back into the room.

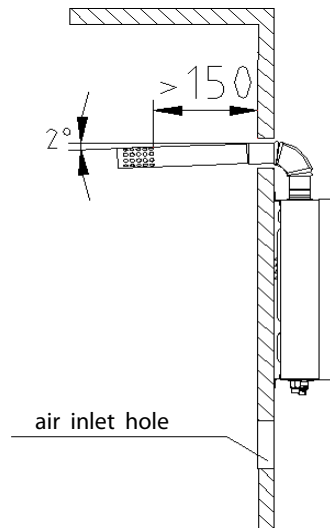

Figure 6.6-1

(B23 ,B53type)

6. INSTALLATION

Flue Duct Installation of Forced Exhaust & Air-Supply Type Gas Water Heater(C13 ,C33 type). This product is a Forced Exhaust & Air-Supply Type gas water heater, it can be used before exhausting the waste gas to the outdoor according to the strictest requirements. It's not allowed to use the gas water heater without operating the flue correctly.

Please follow the below requirements during the installation of flue duct:

(1) Please use the flue supplied by our company, referring to Figure 6.6-3 about the installation method. If the flue duct is too short, you can extend it aptly. Check the flue duct and see if there is any damage or leakage every half a year. Install the flue after the heater body is fixed. First, put the fixed flue through the hole in the wall, then insert the elbow into the exhaust outlet of the heater smoothly, the flue end should have a 2° downward inclination Figure 6.6-3 otherwise the rain may flow into the heater and damage it.

(2) The length of the flue duct should be less than 4m, and the number of elbows should not be more than 4 (one elbow equivalent 1m straight pipe).

(3) The distance between the flue duct and the combustible materials should be more than 150mm. If the flue duct needs to get through the combustible materials or wall, it should use the heat shield material to pack the flue duct with the thickness over 20mm.

(4) No cement between the flue duct and wall for the convenience of maintenance.

(5) The flue duct should be fixed tightly. The connection part could use self-adhesive foil to avoid the waste gas going back into the room.

Flue gas exhaust duct lengths				
Type		Maximum Extension Exhaust-air(m)		Pipes diameter (mm)
		MIN	MAX	
Coaxial System	C13	0,6	6,0	Ø 60/100
	C33	S1= S2		
		0,6 = 0,6	6,0 = 6,0	Ø 80/80

S1 = Air intake - S2 = Flue gas exhaust

Figure 6.6-2

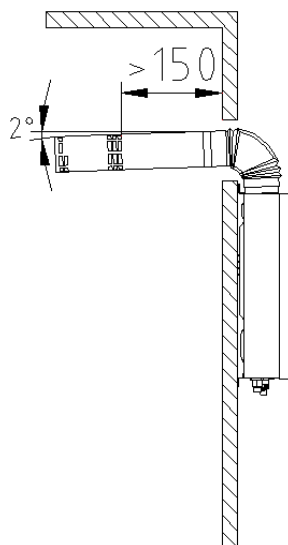

Figure 6.6-3

6. INSTALLATION

Type of air suction/flue gas exhaust ducting		
Combustion air intake from outside		
C13	Flue gas exhaust and air suction duct through external wall in the same range of pressure	
C33	Flue gas exhaust and air suction duct from outside with roof terminal in the same range of pressure	

Figure 6.6-4

6.7 Cautions for flue installation

- Please use the flue supplied by our company. Other flues with different specifications are strictly prohibited. Do not change the specification of the flue.
- The installation of the flue must be correct, otherwise the waste gases will flow back and be dangerous (Figure 6.7).

Wrong installation	Problem caused	Correct installation
	Exhaust gas leak into room	
	Abnormal combustion	
	Work abnormally	

Figure 6.7

6. INSTALLATION

6.8 Conversion instructions

Evolve UK supply this water heater pre-set as a Natural Gas. Please ensure you have the correct model for your requirements.

EVOLVE WH30

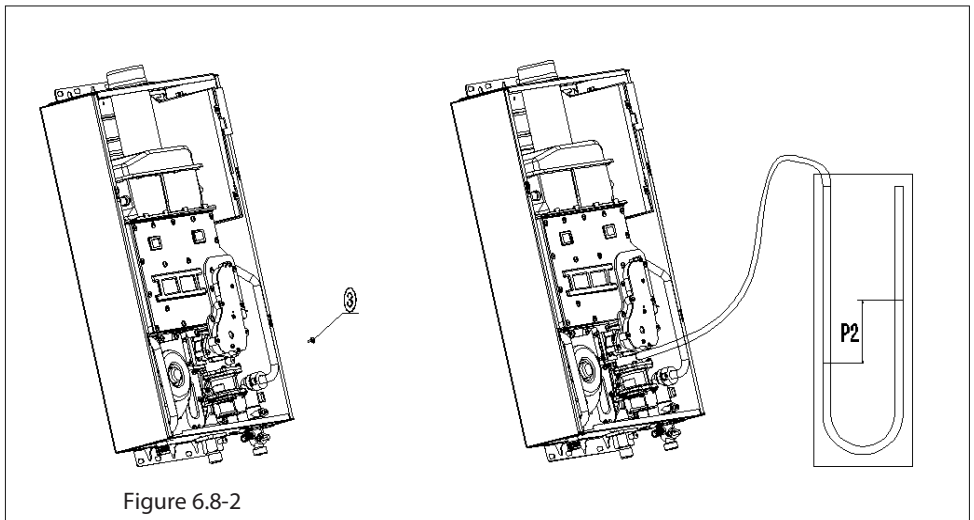
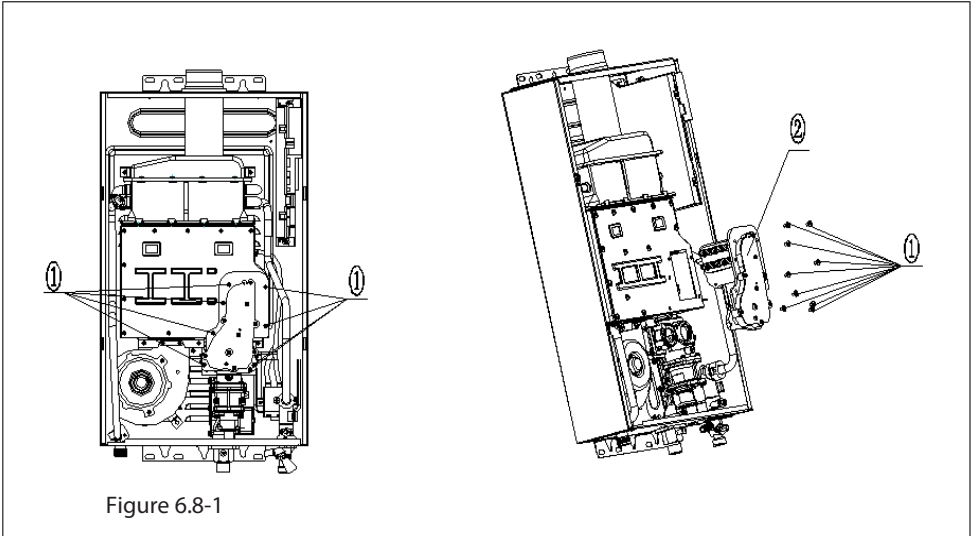

INSTALLATION

6.9 Technical instruction

<p>Step 1 Open front cover</p>	<ol style="list-style-type: none">1. Screw off the front panel and disconnect the display and control unit terminal.
<p>Step 2 Replace gas tube assembly (Figure 6.8-1)</p>	<ol style="list-style-type: none">1. Screw off the gas tube assembly (1) and take it out (2).2. Change to the matched gas ejector tube assembly. Note: It's necessary to examine the air tightness after change, to check the seal ring on the gas control system installed well to prevent gas leakage.
<p>Step 3 Setting flow rate, gas type and model</p>	<ol style="list-style-type: none">1. Connect display and control unit.2. Flow rate selection: Within 10s, after the appliance is electrically fed on but switched off (display blank), press Up and Down keys together for 2s. After the buzzer rings once, "L" shows on the display, which means that you have entered the flow rate selection mode. Press On/Off key to enable the adjustment function, and then Up or Down key to adjust the flow rate. Figure 5.5 shows the flow rate parameter settings.3. Gas type selection: After the gas flow rate is adjusted, press On/Off key to both confirm the modification and enter the next selection interface. The "q" that shows on the display means that you have entered the gas type selection mode. Press On/Off key to enable the selection function, and then Up or Down key to select a gas type. The originally selected type is displayed the first time you press Up or Down key, which is 12 (G20) by default. Figure 6.11 shows the gas type parameter settings.4. Model selection: After gas type is selected, press On/Off key to both confirm the selection and enter the next selection interface. The "F" that blinks on the display means that you have entered the model selection mode (It's the factory default and no need to select, just press on on-off key to skip this step.).

INSTALLATION

<p>Step 4 Secondary pressure adjustment (Figure 5.16)</p>	<ol style="list-style-type: none"> 1. After adjusting the volume and gas type, screw off the secondary pressure screw on the gas control system 3 .And connect the secondary port and U type barometer with rubber pipe. 2. After the system is switched on and it combusts normally, press Up and Down keys together for 5s. The "88" digital tu be displays "26", which means that you have entered the secondary pressure adjustment mode. 3. Then press On/Off key. The high-order position of the "88" digital tube blinks, which means that you can now regulate the secondary pressure of the big endian by the Up or Down key. 4. Press On/Off key, the low-order position of the "88" digital tube blinks, which means that you can now adjust the secondary pressure of the little endian by the Up or Down key. 5. After the adjustment, press On/Off key to confirm and exit from the adjustment mode. 6. After the secondary pressure test compliant, mount the secondary pressure screw and conduct leakage test with fire. Note: After you modify the secondary pressure, wait for 2s or 3s to ensure that the system has recorded the updated the current value. You must verify the upper limit and then the lower limit before you exit. Figure 6.13 and volume.
<p>Step 5 Assemble front cover</p>	<ol style="list-style-type: none"> 1. Check the airproof of finished product ensure no gas leakage. 2. Assemble front cover ,tighten screws of front cover.
<p>Note</p>	<ol style="list-style-type: none"> 1. When replace with new gas tube assembly,notice whether the seal ring on gas control system assembly is fixed well. 2. Check the airproof of finished product ensure no gas leakage. 3. After finish replacing the conversion kits,replace the corresponding labels on the appliance,for example, data plate. 4. This instruction is for reference only,take the material object as the standard.

INSTALLATION

Figure 6.9

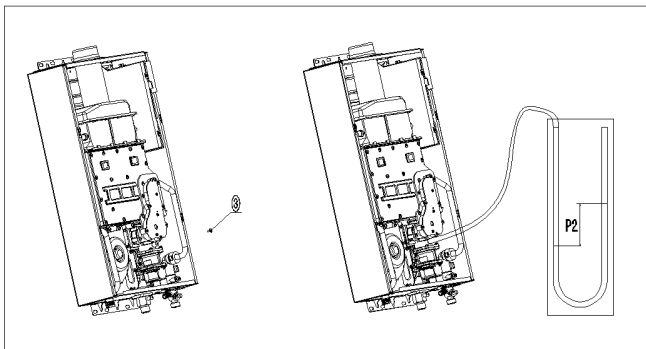

INSTALLATION

6.10 Volume parameter settings

No.	Displayed Symbol	Parameter	Parameter Description
1	L	16	16L

6.11 Gas pressure at the burner

No.	Displayed Symbol	Parameter	Parameter Description
1	q	12	G20
2		22	G30
3		19	G31

6.12 Gas pressure at the burner

NO.	Displayed Symbol	Parameter	Model
2	F	02	WH30 (JSG16ST-S21)

6.13 Gas type setting

Model	Gas type	P2	
		Max	Min
WH30	G20	950 ± 20 Pa	250 ± 10 Pa
	G30	1080 ± 20 Pa	250 ± 10 Pa
	G31	1250 ± 20 Pa	250 ± 10 Pa

Attention: Conversion to other gases shall be carried out by a qualified installer, as described in installation instructions.

7.MAINTENANCE

7.1 MAINTENANCE

- The appliances should be checked and maintained periodically by a competent person.
- Check the gas pipe regularly for any defect. Contact gas safe engineer if you have any doubt. Always check the gas pipe for leaks or damage.
- Always check for leaking water.
- Ask qualified technicians to examine the burner, flue and fan once a year.
- Always check the flame inside the water heater for any abnormal conditions.
- Keep the cover of the water heater clean.
- This product uses a low water pressure switch. When the water pressure is lower than 0.2 bar, the heater cannot be ignited.
- The drain valve will drip when the water pressure is too high, the drain valve will release the water so as to reduce the pressure to protect the heater.
- When the heater is supplying hot water to several points at the same time, the hot water flow would be reduced, or no hot water will be delivered at all.
- When the temperature outside is too low and the exhausted gas meets the cold air, it will condense as white fog. This is normal.
- When the water temperature is too high, set to a lower temperature and reduce the water tap. If the water temperature outlet is too high, please open the tap to reduce the temperature.
- When the water temperature is too low, and the hot water volume is so high so that it exceeds the heater's heating power, the outlet water will be not hot enough, please reduce the water volume.
- In order to ignite immediately, the fan in the appliance will delay running for a long time and then stop automatically. This is normal.
- When you use the multi multi-function shower, the resistance may be too large, and the water inlet pressure will be too low or the water inlet volume will be too little (below the starting –up water volume), there may

be flameout or can not be ignited, please choose the suitable shower function.

- The residual water in the heater may be frozen in the winter, this is bad for the heater, so you must drain the water after use (Please refer to the drain methods).
- In order not to create scaling, please close the gas valve after using the heater, let the hot water out of the appliance. When the outlet of the hot water is cold, close the cold water valve.

7.2 Cleaning

The water heater should be cleaned annually, keep the dust away from flue gas passageway. See the cleaning instructions below (only for service engineer).

1. Turn off power and shut off the gas supply;
2. Wait for the heater to cool down water heater;
3. Remove the front cover, by taking out cover screw;
4. Using compressed air or equivalent to clean the area between the fins and the heat exchanger;
5. Do not unscrew or move any other parts of water heater;
6. After Cleaning, put the front cover back.

7. MAINTENANCE

7.3 Trouble-shooting guidance

Errors Causes	Flame out while using	Non-ignition after opening the cold water valve	Deflagration after ignition	Yellow flame with smoke	Abnormal flame with strange smell	Ignition with strange sounds	Water still not hot, when turning to the high temperature position	Water too hot, when turning to the low temperature position	Flame out when turning to the low temperature position	Flame not out when the cold water valve is closed	Solutions
Main gas valve off		•									Turn on the main gas valve or check you have gas supply to another appliance
Main gas valve half on	•						•				Turn on the main gas valve fully
There is air in the gas pipe		•									Constantly continue to turn on and off a hot water outlet
High supply gas pressure			•			•					Contact the installer to check the gas pressure
Low supply gas pressure	•						•				
Main cold water valve off		•									Turn on the water supply main valve
Frozen		•									Contact your installer for assistance
Pressure of cold water too low	•	•							•		Contact the installer to check water pressure
Adjust water temperature wrongly							•	•			Rotate the water flow adjustment rod appropriately
Air supply not enough	•				•						Improve air exchange , and let more fresh air in
External wind pressure too high	•	•	•								Stop using it
Burner assembly blocked				•	•	•					Contact the manufacturer for guidance
Heat exchanger assembly blocked	•			•	•						The same as mentioned above
Errors in the water control device	•	•					•	•		•	The same as mentioned above

Table 7.3

7. MAINTENANCE

7.4 Explanation of the Error Codes

If during operation the water heaters display shows a flashing fault code, then please follow the below actions.

Fault code will be flashing when there is a fault. On such occasions, please turn off the hot water outlet and then turn on or turn off/then on the monitor, and then turn back on the outlet valve and try a hot water outlet once or twice. If the display still shows the fault code, please be sure to close the water valve, turn off the power and contact your installer or the manufacturers after-sales service.

Error Code	Explanation
01	Inlet water temperature sensor fault
10	Detect a flame signal through pre-check
11	Ignition fails
12	Normal combustion flames out accidentally
13	Thermostat fault protection
32	Fan blocking protection
40	Fan or its drive circuit faulty
50	Over temperature protection (outlet is > 80°C)
51	Over temperature protection (inlet is > 65°C)
60	Outlet water temperature sensor fault

Table 7.4

8. PACKAGING AND ACCESSORIES

Description	Quantity
Gas water heater	1 pc
Expansion rubber plug	2 pc
Expansion screws	1 set
Mounting screws	2 pcs
User manual	1 pc
Self-tapping screws	4 pcs
Flue duct (C13type)	1 set

9. GAS WATER HEATER DISPOSAL AND RECYCLING

9.1 GAS WATER HEATER DISPOSAL AND RECYCLING

The Gas Water Heater and any accessories must be disposed of correctly, separating the different materials for recycling where possible. The installer must dispose of the packaging used to transport the Gas Water Heater



Recycle and dispose of the Gas Water Heater and any accessories in line with the regulations in force. For electronic equipment in particular, please refer to Directive 2012/19/EU.



WARRANTY CERTIFICATE

Title: DOB:

First Name:

Last Name:

Address:

Water Heater Installation Address:

Email:

Contact No:

Account Type: Home Owner Installer

Installer Gas Safe No:

Model No:

Seller:

Purchase Date:

Invoice No:

WARRANTY

10.WARRANTY

10.1 WARRANTY CONDITIONS

Now that you have purchased your Evolve water heater it is important to register the purchase so you receive prompt and efficient handling in the unlikely event your Gas Water Heater requires attention during the 1 year guarantee period.

To register for your free guarantee, please email documents to "sales@yasupplies.co.uk" **within 30 days of your purchase**. Document require Warranty Certificate & Benchmark Commissioning & Warranty Validation Service Record. Attache with the below certificate along with all the gas safe installers details to validate your warranty.

10.2 GUARANTEE CONDITIONS

Evolve products are designed, manufactured and tested to high standards. Evolve will replace (or at their discretion repair) any part found to be defective within 1 years of the original purchase date providing that:

- A) The guarantee is registered within 30 days of purchase.
- B) The product is intended for installation in residential settings only; installing it in a commercial area will void the warranty.
- C) The product is installed by personnel in accordance with our instructions and any national statutory or regulatory requirements.
- D) The defect has not occurred through fair wear and tear.
- E) The product is serviced and maintained only by qualified personnel in accordance with our instructions (the Gas Water Heater must be serviced annually from the date of installation and documentary evidence retained by the owner and made available to the manufacturers authorised agent on request).
- F) The defect is not due to a ventilation failure or to interruptions to the electric, water or gas supply to the system.
- G) The product is installed within the mainland United Kingdom and Ireland.
- H) The benchmark log book is completed satisfactorily and available to the manufacturers on request.

Evolve cannot accept liability for defects arising from neglect, misuse, accident or the failure of any other component of the system of which the product forms part. It is therefore suggested that you contact your installer before making a claim under the conditions of the guarantee as some problems that occur may result from system failure or installation error and are not attributable to a failure of this product. Evolve is not liable for any costs attributable to these actions.

Evolve reserve the right to charge in full for parts and labour for defect any fault that has occurred which is not attributable to a manufacturing defect of the Gas Water Heater or if access has been denied or not available following an agreed appointment.

Please keep this part of the guarantee registration form in a safe place as you will need to produce it to our service personnel in the event of a claim.

ANY REPLACEMENTS OR REPAIR OF APPLIANCE COMPONENTS WILL NOT POSTPONE THE EFFECTIVE DATE AND GUARANTEE TERM ESTABLISHED AT THE TIME OF SALE.

Benchmark Commissioning & Warranty Validation Service Record

It is a requirement that the c is installed and commissioned to the manufacturers' instructions and the data fields on the commissioning checklist completed in full.

To instigate the Gas Water Heater warranty the Gas Water Heater needs to be registered with the manufacturer within one month of the installation. The warranty rests with the end-user (consumer), and they should be made aware it is ultimately their responsibility to register with the manufacturer, within the allotted time period.

It is essential that the Gas Water Heater is serviced in line with the manufacturers' recommendations, at least annually. This must be carried out by a competent Gas Safe registered engineer. The service details should be recorded on the Benchmark Service and Interim Gas Water Heater Work Record and left with the householder. Failure to comply with the manufacturers' servicing instructions and requirements will invalidate the warranty.



www.hhic.co.uk

This Commissioning Checklist is to be completed in full by the competent person who commissioned the Gas Water Heater as a means of demonstrating compliance with the appropriate Building Regulations and then handed to the customer to keep for future reference.

Failure to install and commission according to the manufacturers' instructions and complete this Benchmark Commissioning Checklist will invalidate the warranty. This does not affect the customer's statutory rights.

* All installations in England and Wales must be notified to Local Authority Building Control (LABC) either directly or through a Competent Persons Scheme. A Building Regulations Compliance Certificate will then be issued to the customer.

© Heating and Hotwater Industry Council (HHIC)



www.centralheating.co.uk

GAS FIRED CONTINUOUS FLOW WATER HEATER COMMISSIONING CHECKLIST

This Commissioning Checklist is to be completed in full by the competent person who commissioned the water heater as a means of demonstrating compliance with the appropriate Building Regulations and then handed to the customer to keep for future reference

Failure to install and commission according to the manufacturer's instructions and complete this Benchmark Commissioning Checklist will invalidate the warranty. This does not affect the customer's statutory rights.

Customer name:		Telephone number:	
Address:			
Water Heater Make & Model:			
Serial Number:			
Commissioned by (PRINT NAME):		Gas Safe Register Number:	
Company name:		Telephone number:	
Company address:			
Commissioning date:			
To be completed by the customer on receipt of a Building Regulations Compliance Certificate*:			
Building Regulations Notification Number (if applicable)			
CONTROLS			
Is there a separate temperature control fitted		Yes	No
Have they been explained to the customer		Yes	No
Has the Appliance been set to the required MAX temp.		Yes	No
If NO has the Appliance been set to the required temp.		Yes	No
SYSTEM			
Is there a filter on the incoming mains		Yes	No
Is the system on a secondary return		Yes	No
Has an unvented kit been installed		Yes	No
If yes please record Safety Valve Size and rating		Size	Rating
Does the discharge pipe comply with current building regulations			Yes
Please record location of Pressure Reducing Valve			
Pressure Reducing Valve Setting			
Expansion Vessel Size			
Expansion Vessel Charge Pressure			
Has the system been installed with a storage vessel		Yes	No
DOMESTIC HOT WATER MODE			
Gas Rate at High Fire		m ³ /hr	ft ³ /hr
Burner Pressure		Lo	mbar
Inlet Pressure Dynamic at Hi Fire and all other appliances running		mbar	
Inlet water temp		°C	
Water Heater Set Temperature		°C	
Maximum Flow Rate Achieved		L/min	
Is the installation in a hard water area (above 150mg/L)		Yes	No
If Yes What Type of Scale Reducer has been Fitted			
Hot Water checked at all outlets		Yes	Temp °C
FLUEING			
What type of water heater is fitted		Internal	External
EXTERNAL is the unit mounted fully outside		Yes	No
If NO explain in detail where the appliance is mounted			
INTERNAL does the flueing comply with current standards		Yes	No
If the flueing to manufacturers instructions		Yes	No
CONDENSING WATER HEATERS ONLY			
Has the condensate drain has been installed as per manufacturers instructions and/or BS5446/BS6798		Yes	No
FULL INSTALLATION			
Record the following:		At max rate: CO ppm and CO/CO2 Ratio	
		At min. Rate: (where possible) CO ppm and CO/CO2 Ratio	
Does the hot water system fully comply with the appropriate Building Regulations			Yes
The water heater and associated products have been installed and commissioned in accordance with all manufacturers instructions			Yes
The full operation of the water heater and any controls have been demonstrated to and understood by the customer			Yes
The manufacturers literature including Benchmark Checklist and Service Record, has been explained and left with the customer			Yes
Commissioning Engineer's Signature			
Customer's Signature			
(To confirm satisfactory demonstration and receipt of manufacturer's literature)			

*All installations in England and Wales must be notified to Local Authority Building Control (LABC) either directly or through a Competent Persons Scheme. A Building Regulations Compliance Certificate will then be issued to the customer.



SERVICE RECORD

It is recommended that your heating system is serviced regularly and that the appropriate Service Interval Record is completed. Service Provider
 Before completing the appropriate Service Interval Record below, please ensure you have carried out the service as described in the manufacturer's instructions. Always use the manufacturer's specified spare part when replacing controls.

SERVICE 01	Date:
Engineer name:	
Company name:	
Telephone No:	
Operative ID No:	
Comments:	
.....	
.....	
.....	
Signature	

SERVICE 02	Date:
Engineer name:	
Company name:	
Telephone No:	
Operative ID No:	
Comments:	
.....	
.....	
.....	
Signature	

SERVICE 03	Date:
Engineer name:	
Company name:	
Telephone No:	
Operative ID No:	
Comments:	
.....	
.....	
.....	
Signature	

SERVICE 04	Date:
Engineer name:	
Company name:	
Telephone No:	
Operative ID No:	
Comments:	
.....	
.....	
.....	
Signature	

SERVICE 05	Date:
Engineer name:	
Company name:	
Telephone No:	
Operative ID No:	
Comments:	
.....	
.....	
.....	
Signature	

SERVICE 06	Date:
Engineer name:	
Company name:	
Telephone No:	
Operative ID No:	
Comments:	
.....	
.....	
.....	
Signature	

SERVICE 07	Date:
Engineer name:	
Company name:	
Telephone No:	
Operative ID No:	
Comments:	
.....	
.....	
.....	
Signature	

SERVICE 08	Date:
Engineer name:	
Company name:	
Telephone No:	
Operative ID No:	
Comments:	
.....	
.....	
.....	
Signature	

SERVICE 09	Date:
Engineer name:	
Company name:	
Telephone No:	
Operative ID No:	
Comments:	
.....	
.....	
.....	
Signature	

SERVICE 10	Date:
Engineer name:	
Company name:	
Telephone No:	
Operative ID No:	
Comments:	
.....	
.....	
.....	
Signature	



Sales & Enquiries
01254 427 840
sales@yasupplies.co.uk
www.evolvebathrooms.co.uk
Unit 1, fort street, BB1 5DP Blackburn